

WHEN FULL POWER IS NEEDED



DESCH
Lutex® Clutch/Brake Combination
Type LKB - pneumatically actuated



Technology KB 09 - GB

Lutex® Clutch/Brake Combination

Description



Function

The brake disc is mounted on the press/machine frame whilst the clutch disc is mounted on the flywheel. The piston is mounted on the hub and is free to move axially between the hub and the cylinder. In the “non-air pressure“ state spring tension keeps the brake disc in contact with the cylinder. The brake is on. As air is inflowing into the cylinder the spring tension is overcome and the brake begins to release, the increase in air pressure engages the clutch.

The friction discs are available with either 12-point or 2-point mounting (see schema on page 3). In the 2-point system the mounting points can be either long or short depending upon the machine frame requirements.

Application Area

The pneumatically actuated Lutex® LKB is a dry single plate combined clutch/brake combination (it is referred to in the following text as the C-B-C).

Originally developed for use on presses and shearing machines it is particularly suitable for applications where medium and large inertias are to be accelerated or decelerated. The heat resistant properties

of the friction surfaces enables the Lutex® C-B-C to achieve the high operating cycle required by presses.

Its compact construction allows the C-B-C to be mounted in a very small space between the machine frame and the flywheel.

The C-B-C conforms to the safety requirements of the EN 692/2006.

Features and Benefits of the Lutex® Clutch/Brake Combination (C-B-C):

- Low-maintenance, safe, reliable
- Low inertia
- Large shaft bore
- High heat resistant
- Low air consumption
- High frequency of operation
- Accurate repeatability
- High volume friction surfaces
- Asbestos free friction linings
- 2-point mounting system with plastic collar for noise and vibration absorption
- Quick and easy replacement of the friction discs
- Several methods of mounting the friction discs
- Wide range of brake and clutch torque
- Ability to adjust worn friction discs (on sizes 30 to 75)
- Certificate of conformity to safety regulations
- Application of clamping elements (as an option)
- Completely interchangeable with its Lutex® LPK predecessor

Installation Hints

- The friction surfaces must always be kept grease free
- Ventilation holes should be provided in the machine frame and the fly-wheel to allow air to the friction surfaces
- The bore of the C-B-C is provided with 2 keyways (to DIN 6885 p. 1), diametrically opposite each other (Special keyways are available as an option)
- The 2 air supply bores “d” are 90 degrees displaced to the keyways
- Operating air pressure is 6 bar (maximum air pressure 6,5 bar)
- To simply assembly and disassembly the friction discs are manufactured in 2 halves
- On the brake, the strap with the square bush collar should be mounted at the lower end
- The C-B-C should only be mounted on horizontal shafts. Units for mounting on inclined or vertical shafts are available
- See page 5 for details on shaft sealing

Mounting of the friction disc

Type	brake disc		clutch disc	
	12 - point	2 - point short strap long strap	12 - point	2 - point short strap long strap
LKB	•		•	
LKBZ		•		•
LKBBZ		•	•	
LKBZU			•	•
LKBBZU		•	•	

Type LKB

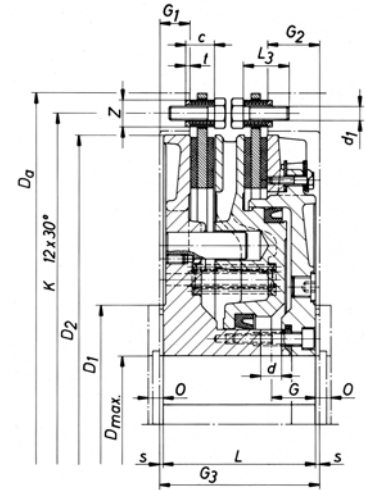

Fig. 1

Type LKBZ

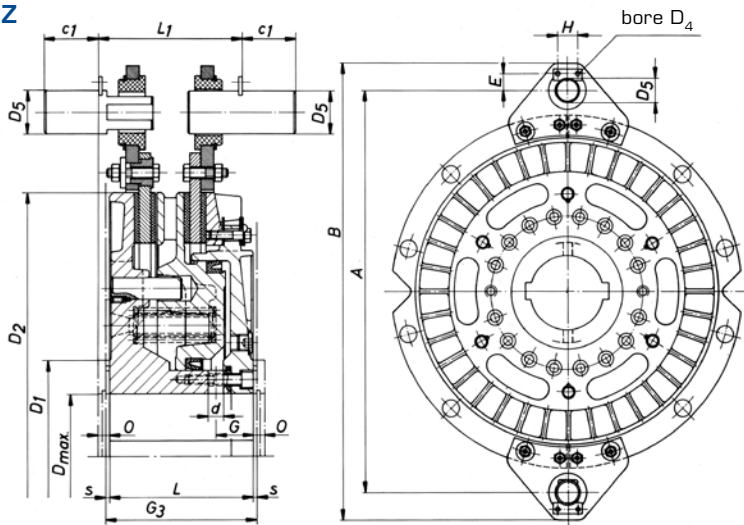

Fig. 2

Type LKBBZ

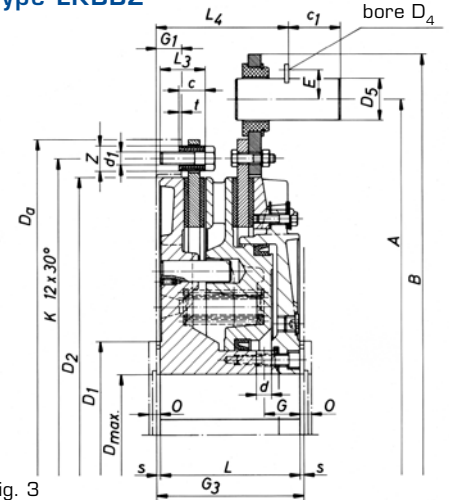

Fig. 3

Type LKBZU

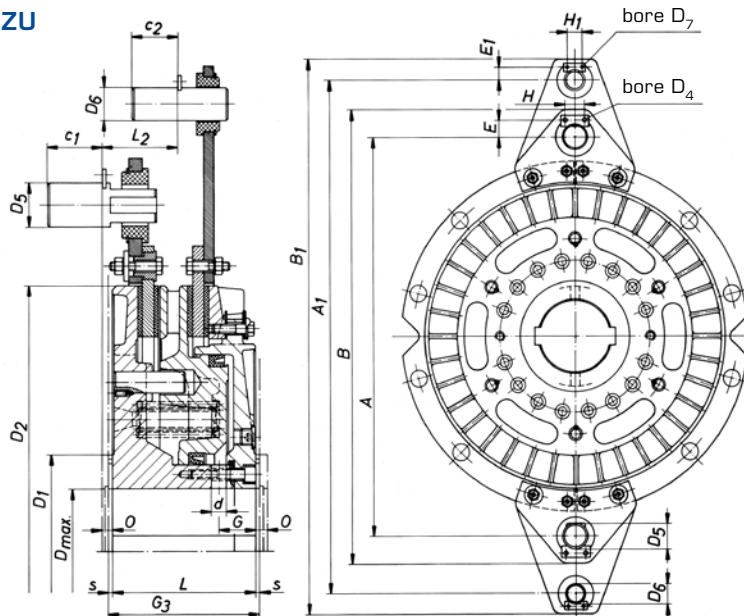

Fig. 4

Type LKBBZU

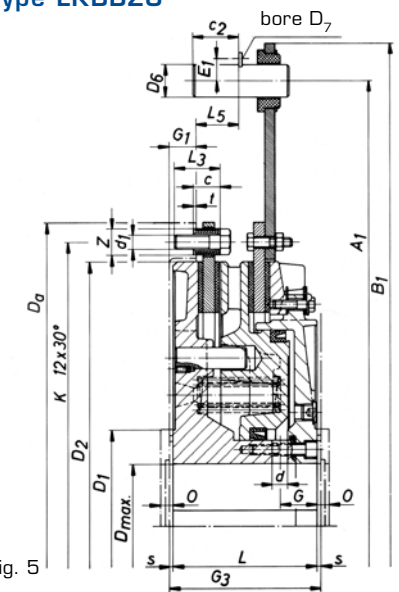

Fig. 5

Technical Data

DRIVE TECHNOLOGY

Size		05	10	15	20	25	30	35	40	45	50	55	60	65	70	75
Clutch ³⁾	T ₀ ¹⁾ Nm	250	400	760	1500	3000	5700	7200	9000	13000	17500	23500	37000	56000	80000	115000
Brake ³⁾	T _s ²⁾ Nm	140	225	430	850	1700	3200	4100	5100	7400	10000	13400	21000	32000	46000	65000
Weight approx. kg	LKB	4,8	7,3	13,0	26,0	48,5	75	95	115	160	240	340	560	700	1000	1400
	LKBZ	5,2	8,5	15,5	29,0	52,5	88	109	130	179	275	390	625	765	1094	1520
	LKBZU	5,3	8,7	16,0	29,5	53,5	89	111	132	183	282	397	631	771	1102	1540
	LKBBZ	5,0	7,9	14,3	27,5	50,5	82	102	123	170	258	365	593	733	1048	1460
	LKBBZU	5,1	8,1	14,8	28,0	51,5	83	104	125	174	265	372	599	739	1057	1480
J inside	kgm ² all types	0,008	0,02	0,055	0,175	0,55	1,3	2,0	2,75	4,63	8,75	15,0	28,8	48,8	85,5	137,7
J outside	LKB/LKBBZ/LKBBZU	0,003	0,005	0,025	0,0875	0,2	0,625	0,925	1,25	2,13	4,0	7,5	14,5	14,5	25,0	47,5
	LKBZ/LKBZU	0,005	0,0075	0,055	0,138	0,375	1,225	1,6	2,08	3,5	7,25	11,8	24,5	24,5	39,0	77,5
Cylinder volume dm ³	new ⁴⁾	0,05	0,06	0,09	0,17	0,3	0,5	0,65	0,8	1,2	1,5	1,9	3,3	3,5	5,0	6,0
	worn ⁴⁾	0,08	0,1	0,15	0,3	0,55	0,9	1,1	1,3	2	2,5	3,1	5	6,5	8,5	10,0
Max. speed	rpm ⁵⁾	2800	2800	2500	1800	1400	1200	1100	1000	900	800	700	600	600	550	500
Linear dimensions in mm	A JS 10 ⁶⁾	230	250	315	390	495	610	645	695	770	880	970	1140	1140	1300	1465
	A ₁ JS 10 ⁶⁾	305	325	410	490	635	790	830	885	990	1135	1235	1450	1450	1645	1855
	B	262	282	360	435	560	695	730	780	870	1000	1090	1280	1280	1460	1625
	B ₁	337	357	442	522	680	855	895	950	1075	1235	1335	1570	1570	1790	1995
	c	9	11	12	15	19	22	27	27	28	35	36	40	40	50	50
	c ₁	25	20	35	35	45	50	50	50	60	70	70	90	90	90	110
	c ₂	25	20	20	20	35	45	45	45	50	60	60	70	70	70	90
	E	11,0	11,0	16,0	16,0	20,0	27,0	27,0	27,0	29,5	38,5	38,5	44,5	44,5	44,5	50,5
	E ₁	11,0	11,0	11,0	11,0	16,0	20,0	20,0	20,0	27,0	29,5	29,5	38,5	38,5	38,5	45,5
	H	20	20	25	25	25	35	35	35	35	45	45	45	45	45	45
	H ₁	20	20	20	20	25	25	25	25	35	35	35	45	45	45	45
	G	17,0	18,0	20,0	22,0	29,0	32,0	37,5	38,0	42,5	48,0	55,0	65,0	70,0	75,0	90,0
	G ₁	11,0	12,0	15,0	18,0	22,5	26,5	29,5	29,5	31,0	35,5	38,5	45,0	49,0	54,0	61,0
	G ₂	17,0	21,0	23,0	30,5	36,5	42,5	48,0	49,5	56,0	64,5	72,0	85,0	141,0	144,0	180,0
	G ₃	56,0	64,0	73,0	90,0	110,0	135,0	150,0	155,0	170,0	195,0	215,0	260,0	320,0	350,0	410,0
	L	50,0	58,0	65,0	82,0	100,0	125,0	140,0	145,0	160,0	185,0	205,0	250,0	310,0	340,0	400,0
L ₁	55,0	62,0	78,0	95,0	112,0	135,0	148,0	155,0	165,0	186,0	202,0	248,0	257,0	288,0	325,0	
L ₂	26,5	30,0	38,0	50,0	52,0	66,0	75,0	82,0	83,0	98,0	110,0	145,0	148,0	172,0	170,0	
L ₄	55,5	58,0	72,0	86,0	104,0	127,0	140,0	145,0	155,0	176,0	192,0	233,0	242,0	273,0	308,0	
L ₅	13,0	14,0	17,0	23,0	21,5	31,5	37,5	47,0	42,0	52,5	61,5	87,5	84,0	103,0	92,0	
s	3	3	4	4	5	5	5	5	5	5	5	5	5	5	5	
t	2	2	2	3	3	3	3	3	3	5	5	5	5	5	5	
O	7	7	10	13	13	13	13	13	13	15	15	15	20	20	22	
Diameter in mm	D _a	196	220	275	347	435	535	570	620	680	775	865	1000	1000	1150	1290
	D ₁	80	85	105	125	155	175	185	190	210	245	280	320	320	365	420
	D ₂	166	188	235	304	380	465	497	543	593	675	755	885	885	1005	1140
	D ₄ ISO k6 ⁶⁾	4,5	4,5	5,5	5,5	5,5	6,5	6,5	6,5	6,5	8,5	8,5	8,5	8,5	8,5	8,5
	D ₅ ISO k6 ⁶⁾	14,0	14,0	22,0	22,0	30,0	40,0	40,0	40,0	45,0	55,0	55,0	65,0	65,0	65,0	80,0
	D ₆ ISO k6 ⁶⁾	14,0	14,0	14,0	14,0	22,0	30,0	30,0	30,0	40,0	45,0	45,0	55,0	55,0	55,0	65,0
	D ₇	4,5	4,5	4,5	4,5	5,5	5,5	5,5	5,5	6,5	6,5	6,5	8,5	8,5	8,5	8,5
	d	7	8	8,5	12	14	14	18	18	18	20	20	24	28	30	32
	d1 ⁷⁾	M5	M5	M6	M8	M10	M14	M14	M14	M14	M16	M20	M24	M24	M24	M30
	xL ₃	x 16	x 20	x 20	x 25	x 35	x 40	x 45	x 45	x 45	x 50	x 60	x 70	x 70	x 70	x 90
	K JS 10 ⁶⁾	182	205	255	325	408	500	536	584	640	725	810	945	945	1080	1220
	Z - _{0,1}	10	10	12	15	18	25	25	25	30	35	40	40	40	50	50
D _{max} (ISO H7) ⁸⁾	35	40	52	70	90	110	115	125	140	160	180	210	210	240	270	
keyway DIN 6885	20	25	35	40	45	45	60	60	70	70	80	90	90	130	165	
D _{min} (ISO H7)																

In the range of max. speed (0,7 x n_{max}) we recommend dynamical balancing.

1) T₀ = static torque at p = 6 bar

2) T_s = dynamic torque

3) Alteration of clutch/brake torque relation possible. Dates on request

4) Type with reduced cylinder volume on request

5) Not permitted for operation with single strokes

6) Tolerances for connecting parts

7) Self-locking screws

8) Clamping elements on request

Air Supply

Rotor size R	G ^{3/8}	G ^{1/2}	G ^{3/4}	G1	G1 ^{1/4}	G1 ^{1/2}	G2
Part number	653	654	655	656	657	658	659
Max. speed [rpm]	2800	2500	1400	1200	800	700	600
A	26,5	35,5	37,5	37,5	42,0	42,0	51,0
LM	14	15	15	15	22	22	25
LR	12	12	16	18	20	22	25
D	38	55	65	65	88	88	110
M	M 16	M 35x1,5	M 35x1,5	M 35x1,5	M 50x1,5	M 50x1,5	M 65x1,5
p ^{H7}	20	40	40	40	60	60	70
L5	81,5	115,5	123,5	125,5	149,0	151,0	214,0
Suitable for Lutex® LKB-...	03-10	10-20	20-30	25-40	45-60	55-65	65-75

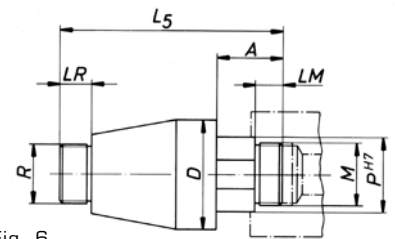

Fig. 6

Direct connection of the press safety valve or the electromagnetic valve with the rotating air supply is possible.

A rotary air supply system for higher speed is available as an option.

Shaft Sealing

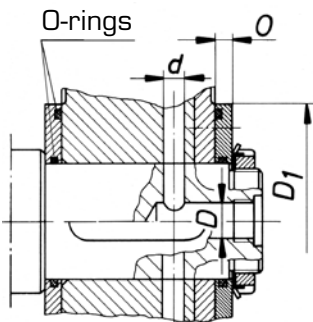

Fig. 7

Cover seal is only possible with a closed keyway

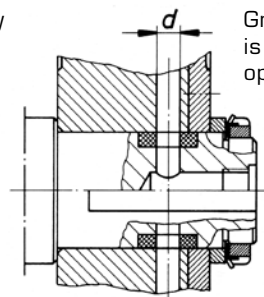

Fig. 8

Grooved shaft seal is possible with an open keyway

The diameter "D" of the shaft bore should be approximately 1.4 times that of the air supply bore, diameter "d".

Examples of Installation

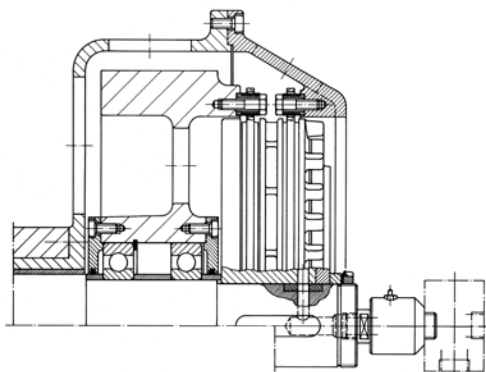

Fig. 9 LKB

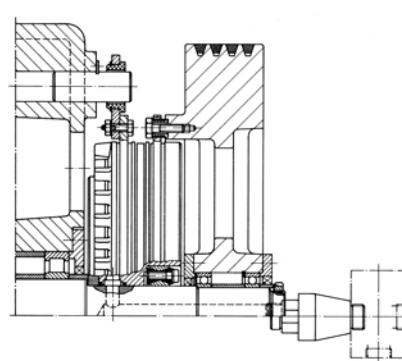

Fig. 10 LKBBZ

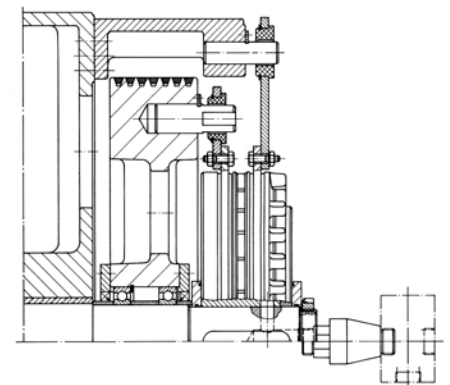

Fig. 11 LKBZU

Other Lutex® Products for Press Drives

Lutex® LS

pneumatically actuated clutch/brake combination with high torque at small dimensions

Lutex® HKB

hydraulically actuated clutch/brake combination

DESCH Complete Press Drive KA

complete press drives (either hydraulically or pneumatically operated) together with planetary gearbox and flywheel

DESCH Complete Press Drive KAS

complete press drives with hydraulically actuated clutch and brake, with planetary gearbox, flywheel and additionally with an engageable gear step

Further Components

flywheels, pulleys and accessories



DRIVE TECHNOLOGY

Product Range

Friction Clutches

Planox® friction clutches
 Conax® friction clutches
 Centrex® centrifugal clutches

Flexible Couplings

Hadeflex® couplings
 Habix® couplings
 Orpex® couplings
 DESCH Flex couplings
 DESCH HRC couplings

Rigid Couplings

Press Drives

Lutex® clutch/brake combinations
 Complete press drives

Gears

Planetary gears
 Special gears

Complete Transmission Solutions

Flywheel back gears for no-delay units
 Drive stations for stretcher
 Levelling units
 Back gears with engageable/
 disengageable clutches

Belt Drives

V-belt pulley drives
 Timing belt drives
 Flat belt drives
 V-belt pulley drives
 with taper bushes
 V-belt pulley and flywheels
 to customers' specification
 V-belts and timings belts
 Bolt-on-hubs
 Weld-on-hubs

Bearings

Grease lubricated plain bearings

Telephone numbers of our head office in Arnsberg

		Telephone	Fax
DES	DESCH Engineering Service	+49 29 32 300-200	300-154
DPC	DESCH Power Transmission Center	+49 29 32 300-218	300-830
DCT	DESCH Clutch Technology	+49 29 32 300-170	300-50
DGP	DESCH Gearbox and Press Drives	+49 29 32 300-153	300-811



DESCH is a member



DESCH Drive Technology
 PO Box 14 40
 D-59753 Arnsberg/Germany
 Kleinbahnstraße 21
 D-59759 Arnsberg/Germany
 Telephone +49 29 32 - 3 00 - 0
 Fax +49 29 32 - 3 00 - 899
 Internet www.desch.de
 E-mail info@desch.de

DESCH Drive Technology
 Limited Partnership
 240 Shearson Crescent
 Cambridge, Ontario
 Canada N 1T 1J6
 Telephone +1800 - 2 63 18 66
 +1519 - 6 21 45 60
 Fax +1519 - 6 23 11 69
 Internet www.desch.on.ca
 E-mail desch@desch.on.ca

DESCH Drive Technology
 Ufficio di rappresentanza in Italia
 Via Cavriana, 3
 I-20134 Milano
 Telephone +3902 - 7 39 12 80
 Fax +3902 - 7 39 12 81
 Internet www.desch.de
 E-mail desch.italia@desch.de

www.desch.de