

Permanent Magnetic Clutches & Brakes

GERWAH
You Can Rely On Us!



GERWAH[®]

GERWAH The Company

Gerwah GmbH was founded in 1980. The idea of new, innovative products has made Gerwah a recognized partner in the machine tool industry. dynamic, spirited and fast growing company with clear goals and open mind that is reflected in the architecture of our new headquarters.

Our Goals

- To add value for our customers by providing innovative product solutions
- To develop solutions in cooperation with our customers
- Satisfied customers

Our Advantages

- Know-how, innovative designs and cutting edge manufacturing plants
- Customer oriented employees
- Technical assistance and service, both locally and internationally
- Qualified sales force
- Economic stability
- Worldwide presence with subsidiaries and dealers



Our new headquarters in Grosswallstadt, Germany



GERWAH - You Can Rely On Us!

We are certified according to DIN EN ISO 9001 (Cert.-No. 0063-D)

GERWAH

Magnetic Clutches Advantages at a glance



Precise torque limitation

from 0,0 to 1000 Nm (synchronous clutch)

- Easy and fast adjustable torque infinitely adaptable to your requirements
- Even for extreme high rotation speeds
- Independent of age and operation

Unlimited number of overload cycles

- Absolutely abrasion-free
- Rated torque level remains ever constant

Superior hygiene requirements: no abrasion

- No working material means or external suppliances
- Also available in high-grade steel

Superior transmission with application of hysteresis clutches

- Constant and soft slipping at torque limitation
- "Soft starts" - smooth starting moments
- The shafts to be connected can be operated with different rotation speed
- Contact-free power transmission

High-tech torque transmission

GERWAH-magnetic clutches do not transmit torques through mechanical connections like their mechanical counterparts but by using magnetic force. It has to be distinguished between synchronous- and hysteresis clutches according to the function principle in use.

The synchronous clutch

Synchronous clutches transmit torques due to magnetic force, which is produced through periodically arranged, opposite lying permanent magnets. According to the size of the clutch torques up to 1000 Nm can be transmitted. When exceeding the rated torque level the magnetic force breaks off, the clutch slips through and now can only transmit a minor rest torque. The synchronous clutch owes its name to its nature, only able to transmit torque if a synchronous action of the connecting system is granted.

The hysteresis clutch

At this type of clutch, one half of the clutch is coated with a hysteresis lining instead with a permanent magnet. This hysteresis material acts similar according to the permanent magnet but through the hysteresis lining poles can be changed with an extrem low power demand. In case the rated torque level of the clutch exceeds, the clutch begins to slip through. Thereby the hysteresis material takes up energy from the starting system, due to the permanent changing of poles caused by the passing by of the permanent magnets, and transforms this kinetic power into heat which is conducted away into the environment.

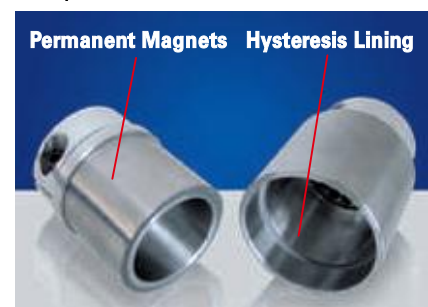

Please do not hesitate to contact us if you wish further information concerning this new and trend-setting technology. We would be pleased to give you more detailed information!

Permanent Magnetic Clutches Product Range

GERWAH-magnetic clutches offer a greater variety and due to their flexible design can be used for many applications. The creative technical designer will find a wealth of possibilities enabling him to solve former problems more easily and in a more

elegant way. Our technical department is pleased to be at your disposal helping you design the most favourable clutch fulfilling all requirements of your desired field of application.

Magnetic Hysteresis Clutches



Compact construction; easy adjustable torque; a completely stainless-steel version possible; flexible attachment possibilities
Technical Data Page 5



Narrow construction; easy adjustable torque; a completely stainless-steel version possible; flexible attachment possibilities
Technical Data Page 6



Flexible application; torque adjustable within limits; This clutch consists of two clutch halves and is not bearing-mounted!
Technical Data Page 7

Magnetic Synchronous Clutches



Low construction volume; flexible application; torque adjustable within limits; This torque consists of two clutch halves and is not bearing-mounted!
Technical Data Page 8



Short length; intermating; free of wear; This clutch consists of two clutch halves and is not bearing-mounted
Technical Data Page 9

Special models of hysteresis and synchronous clutches

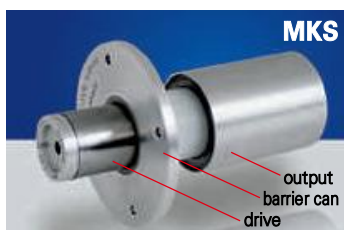

We design magnetic clutches according to your special requirements and are pleased to offer you our advice!

Example slot-free clutch MKS
Special model of type MKD with extended air slot. Thereby torque transmission into a hermetically sealed container is possible. Possible field of application: driving of pumps.

Range of applications

- Bottle cap plants
- Roll-up and unroll systems
- Brakes
- Test procedures
- Packing technology
- As safety clutch in e.g. extrusion plants, shredders, or similar
- Driving of pumps
- For "soft starts"
- As safety clutch with "smooth" overload transition
- Food industry
- Cosmetic production
- Medical engineering

The information in this catalogue contains product descriptions and does not constitute any specific promises.

The user must define and check the technical features for use in each specific application. All data is subject to

change without notice. Only individual agreements are binding for products supplied.

GERWAH

Permanent Magnetic Hysteresis Clutch Series HSV

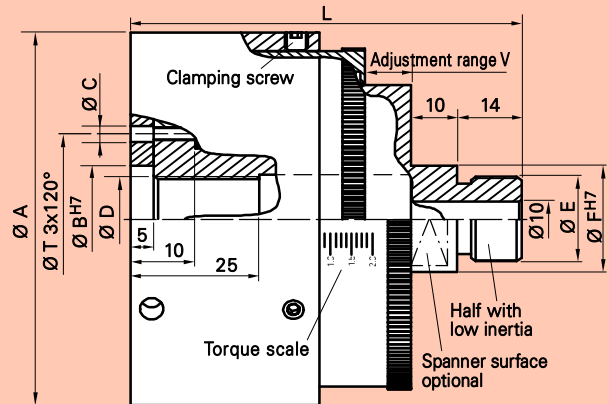

Technical Data Series HSV

Type				1	2	4
Torque (adjustable) ¹⁾	(Nm)	ME	Version a	0,4 - 1,0	0,8 - 2,0	1,6 - 4,0
			Version b	0,2 - 0,5	0,1 - 1,3	0,2 - 2,6
Max. power dissipation (thermal limited) ²⁾	(W)	Pv		15 (20)	23 (30)	30 (40)
Max. rotating speed ³⁾	(min ⁻¹)	n _{max}		4000	3500	3000
Max. temperature of surrounding air	(°C)	T		0 - 40	0 - 40	0 - 40
Weight	(kg)	m _{ges}		0,8	1,2	1,9
Inertia outside half	(10 ⁻³ kgm ²)	J _{out}		0,36	0,62	1,62
inside half	(10 ⁻³ kgm ²)	J _{in}		0,13	0,25	0,79
Max. forces radial	(N)	F _{rad}		200	300	400
axial	(N)	F _{ax}		150	200	250

Standard model with aluminium housing, with stainless steel bearings, rare earth magnets, sintered hysteresis material

Dimensions (mm) Series HSV

Type	1	2	4
Ø A	73	79	105
Ø B	18	25	30
Ø C	M3	M4	M4
Ø D ⁴⁾	M16 x 1,5	M18 x 1,5	M24 x 1,5
Ø E ⁴⁾	M16 x 1,5	M18 x 1,5	M24 x 1,5
Ø F	20	25	30
Ø T	25	33	48
L	70	85	85
V	8	10	10

1) Other torque values on request

2) In clamps: max power loss using high temperature permanent magnets

3) Depending on overload ratio and torque

4) Other dimensions on request

- Range of applications**
- Bottle capping machines
 - Wind up and unwind systems
 - Brakes
 - Test procedures

GERWAH

Permanent Magnetic Hysteresis Clutch Series HLV

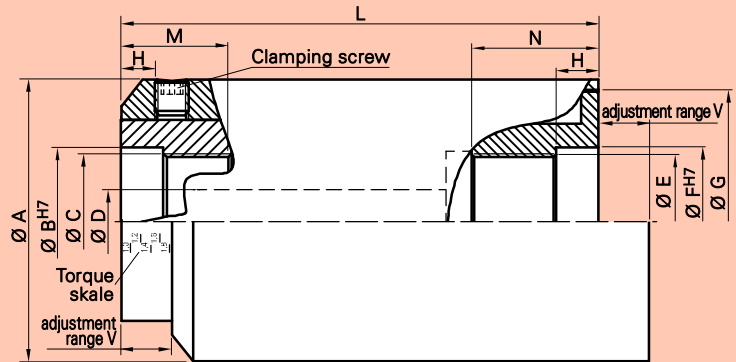

Technical Data Series HLV

Type			1	2	4
Torque (adjustable) ¹⁾	(Nm)	ME	0,4 - 1,0	0,7 - 2,0	1,5 - 4,0
Max. power dissipation ²⁾	(W)	Pv	18 (25)	25 (35)	40 (55)
Max. rotating speed ³⁾	(min ⁻¹)	n max	4000	3500	3000
Max. temperature of surrounding air	(°C)	T	0 - 40	0 - 40	0 - 40
Weight	(kg)	m _{ges}	1,2	1,6	3,2
Inertia outside half	(10 ⁻³ kgm ²)	J _{out}	0,43	0,87	2,68
inside half	(10 ⁻³ kgm ²)	J _{in}	0,09	0,21	0,549
Max. forces radial ⁵⁾	(N)	F _{rad}	150	200	250
axial	(N)	F _{ax}	100	150	200

Standard model made of stainless steel, with stainless steel bearings, rare earth magnets, sintered hysteresis material

Dimensions (mm) Series HLV

Type	1	2	4
Ø A	55	60	80
Ø B	30	35	40
Ø C ⁴⁾	M27 x 1,5	M32 x 1,5	M38 x 1,5
Ø D	10	15	20
Ø E ⁴⁾	M27 x 1,5	M32 x 1,5	M48 x 1,5
Ø F	30	35	55
Ø G	50	55	74,5
H	8	10	12
L ⁶⁾	90	113	136
M	20	25	29
N	20	25	40
V	15	18	20

1) Other torque values on request

2) In clamps: max power loss using high temperature permanent magnets

3) Depending on overload ratio and torque

4) Other dimensions on request

5) F_{rad} applied in max. 40 mm from clutch end

6) For assembly the total length (with L + V) must be considered

Range of applications

- Bottle capping machines
- Packaging technology

GERWAH

Permanent Magnetic Hysteresis Clutch Series HKD



The coupling consists of two separated halves which have to be supported by the customer!

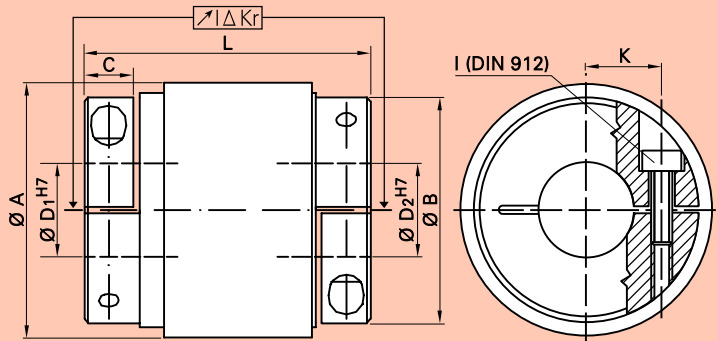

The permanent magnetic hysteresis clutch consists of **two separated halves** which are telescoped. In the inner part of the outside hub the hysteresis material is coated on, on the outside of the inner hub the permanent magnets are attached. The maximum transmittable torque

of the clutch can be changed by modifying the hub submergence. At overload status the clutch will slip through in a **"sliding"** manner, contact free and without any abrasion. The clutch is connected with the shaft by clamping hubs.

Technical Data Series HKD

Type		2	4	10	18	30	60	150
Torque	(Nm) T _{KN}	0,1 ^{1) 2)}	0,2 ^{1) 2)}	0,4 ^{1) 2)}	0,9 ^{1) 2)}	1,2 ^{1) 2)}	2,5 ^{1) 2)}	5,0 ^{1) 2)}
Max. power dissipation	(W) P _v	4	5	7	12	14	20	30
Inertia approx.	outer part (10 ⁻³ kgm ²) J _{out}	0,018	0,04	0,07	0,14	0,20	0,87	1,8
	inner part (10 ⁻³ kgm ²) J _{in}	0,005	0,02	0,04	0,08	0,11	0,57	1,3
Weight approx.	outer part (kg) m _{out}	0,12	0,15	0,18	0,28	0,34	0,68	1,7
	inner part (kg) m _{in}	0,07	0,11	0,16	0,25	0,27	0,51	1,6
Max. app. rad. misalignment ³⁾	(mm) K _r	0,2	0,2	0,2	0,2	0,2	0,2	0,2
Max. rotating speed ⁴⁾	(min ⁻¹) n _{max}	10000	9000	8000	7000	6000	5000	4000
Tightening torque of retaining screws	(Nm) M _A	2	3	3	6	12	30	50

Dimensions (mm) Series HKD

Type		2	4	10	18	30	60	150
L		55	58	58	78	88	107	130
Ø A		31	38	46	51	56	69	84
Ø B		25	32	40	45	47	57	68
C		8,2	10	10	12	15	19,5	21,5
Ø D ₁ H7 / Ø D ₂ H7	min. - max.	3 - 10	6 - 16	6 - 19	10 - 20	10 - 20	14 - 23	20 - 28
K		9	11,5	15,5	17,5	16	20	24
I		M3	M4	M4	M5	M6	M8	M10
M	(length of magnets)	20	20	20	30	30	40	50

Clamping hubs 2 to 60 made of aluminium
Clamping hubs 150 made of steel
Other material on request

- 1) Other torque values on request
- 2) Torque value adjustable by hub submergence
- 3) Bigger approved misalignment on request
- 4) Max. permanent slip speed limit depends on frequency and ratio of slippings

Ordering data

HKD 30	-	15H7	-	12H7	-	xx
Type		Bore diameter D ₁		Bore diameter D ₂		Further details e.g. special material, keyway

Range of applications

- As brake for "soft starts"
- As safety clutch with "smooth" overload transition

GERWAH

Permanent Magnetic Synchronous Clutch Series MKD



The coupling consists of two separated halves which have to be supported by the customer!

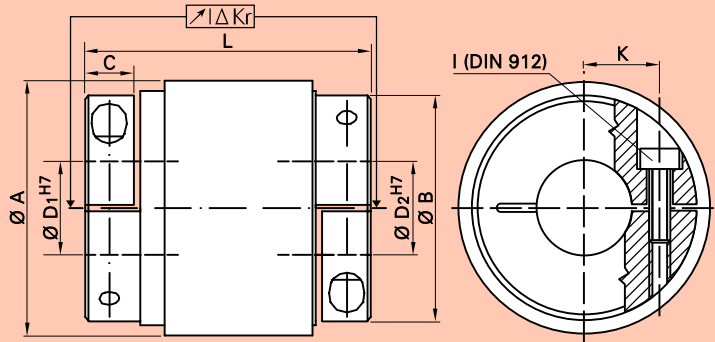

The permanent magnetic synchronous clutch consists of **two separated halves** which have to be supported by the customer and then are telescoped. In the inner part of the outside hub and on the outside of the inner hub the permanent magnets are attached. The maximum

transmittable torque of the clutch can be changed by modifying the hub submergence. At overload status the clutch will slip through in a **"bucking"** manner, contact free and without any abrasion. The clutch is connected with the shaft by clamping hubs.

Technical Data Series MKD

Type		2	4	10	18	30	60	150	300
Torque	(Nm) T _{KN}	1,2 ^{1) 2)}	2,5 ^{1) 2)}	5 ^{1) 2)}	9 ^{1) 2)}	13 ^{1) 2)}	30 ^{1) 2)}	60 ^{1) 2)}	150 ^{1) 2)}
Torsional stiffness approx.	(Nm/rad) C _{T dyn}	3	10	25	45	83	250	610	2300
Inertia approx.	outer part (10 ⁻³ kgm ²) J _{out}	0,018	0,038	0,08	0,14	0,21	0,60	1,8	6,7
	inner part (10 ⁻³ kgm ²) J _{in}	0,005	0,014	0,04	0,07	0,10	0,30	1,6	5,0
Weight approx.	outer part (kg) m _{out}	0,11	0,15	0,20	0,28	0,35	0,70	1,9	3,4
	inner part (kg) m _{in}	0,07	0,11	0,16	0,23	0,28	0,53	1,4	3,1
Max. app. rad. misalignment ³⁾	(mm) K _r	0,4	0,4	0,4	0,4	0,4	0,4	0,4	0,4
Max. rotating speed	(min ⁻¹) n _{max}	10000	9000	8000	7000	6000	5000	4000	3000
Tightening torque of retaining screws	(Nm) M _A	2	3	3	6	12	30	50	90

Dimensions (mm) Series MKD

Type		2	4	10	18	30	60	150	300
L		55	58	58	78	88	107	130	146
Ø A		31	38	46	51	56	67	84	115
Ø B		24	32	40	45	47	57	68	96
C		8,2	10	10	12	15	19,5	21,5	26
Ø D ₁ H7 / Ø D ₂ H7	min. - max.	3 - 10	6 - 16	6 - 19	10 - 20	10 - 20	14 - 23	20 - 28	32 - 40
I		M3	M4	M4	M5	M6	M8	M10	M12
K		9	11,5	15,5	17,5	16	20	24	32
M	(length of magnets)	20	20	20	30	30	40	50	60

Clamping hubs 2 to 60 made of aluminium
Clamping hubs 150 and 300 made of steel
Other material on request

- 1) Other torque values on request
- 2) Torque value adjustable by hub submergence
- 3) Bigger approved misalignment on request
- 4) Axial misalignment changes the submergence and thus the torque; however, axial displacement in one direction is possible without limitations

Ordering data

MKD 30 - 15H7 - 12H7 - xx

Type

Bore diameter D₁

Bore diameter D₂

Further details e.g. stainless, other torques

Range of applications

- As safety clutch
- Other applications that require high torque and limited dimensions

GERWAH

Permanent Magnetic Safety Clutch Series MK/SV



The coupling consists of two separated halves which have to be supported by the customer!

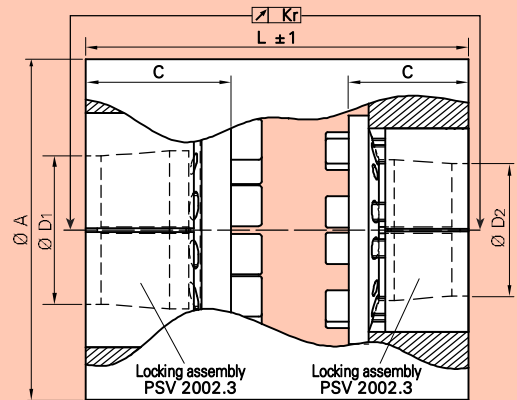

Technical Data Series MK/SV

Type			100		200		500	
	Version a	Version b	Version a	Version b	Version a	Version b	Version a	Version b
Torque ¹⁾	(Nm)	M	50	100	100	200	250	500
Max. rotation speed	(min ⁻¹)	n _{max}	6000	6000	4000	4000	3000	3000
Max. temperature of surrounding air (°C)		T	0 - 60	0 - 60	0 - 60	0 - 60	0 - 60	0 - 60
Weight	(kg)	m _{ges}	3,1	4,0	5,7	7,3	11,9	14,4
Max. app. radial misalignment ²⁾	(mm)	K _r	0,4	0,4	0,4	0,4	0,4	0,4
Inertia	outer part	(10 ⁻³ kgm ²) J _{out}	2,7	3,7	9,1	12,2	37,2	47,3
	inner part	(10 ⁻³ kgm ²) J _{in}	1,0	1,6	4,1	6,2	21,3	29,7
Tightening torque of screws	(Nm)	T _A	18	18	18	18	18	18

Dimensions (mm) Series MK/SV

Type	100		200		500	
	Version a	Version b	Version a	Version b	Version a	Version b
Ø A	94	94	129	129	189	189
C	31	31	31	31	31	31
L	75	115	75	115	75	115
Ø D ₁ / Ø D ₂	20	20	30	30	35	35
min. - max.	20 - 25	20 - 25	20 - 40	20 - 40	20 - 40	20 - 40

1) Lower torque values on request

Range of applications • As safety clutch in e.g. extrusion plants, shredders, or similar

Magnetic Clutches Applications

Selected fields of application suitable for GERWAH Magnetic Clutches



As safety clutches

GERWAH magnetic clutches offer excellent protection against overload. They guarantee long life even for most difficult systems through their abrasion-free and precise operation.

In bottle capping systems

Owing to technical superiority and elegant functionality compared to all other solutions, hysteresis clutches have become well established worldwide in this field of application. Precise torque limitation, abrasion-free application, constant and jerkfree attitude within the overload area as well as the stainless steel version prove to be fundamental advantages in this operational field. Specially our two models HSV and HLV have proven themselves as excellent for the use in the bottling machines.



In wind-up and unwind applications

Within this field of application it is of essential importance that the quality of exact and constant torque limitation is granted. GERWAH hysteresis brakes absolutely fulfill these requirements.

As brakes

Especially for the application as a brake the GERWAH magnetic clutches show themselves as manifold suitable: as a load for engines for example, or even as generators for test blocks and furthermore in many other application fields. Through their abrasion-free operation, GERWAH hysteresis clutches offer fundamental advantages over friction based clutch systems.

Within the progress technology

Due to their ability to transmit torque even by going through magnetic non-conducting materials, GERWAH magnetic clutches offer unique possibilities for sealing, for example in pumps.



GERWAH

Magnetic Clutches Explanation

At overload status the hysteresis clutches and brakes slip through. The losses (due to the slip rotation speed and torque) are transformed into heat. If the dissipation power exceeds the quantity of heat which can be conduc-

ted to the environment, the clutch (brake) will superheat. With the formula on the right side it is possible to check if the chosen max. power loss of the clutch (brake) is sufficient for the desired operation.

$$P_V = \frac{T \times n_s}{9,55} \times s$$

P_V : max. power loss (W)
 T : applied torque (Nm)
 n_s : slip rotation speed (min^{-1})
 s : slip (-)

Example 1: A hysteresis brake of type HSV 2 ($P_{V\text{max}} = 23 \text{ W}$) is applied as spool brake ($s = 1$). The applied torque shall be 1,5 Nm. Which rotation speed is allowed permanently, without superheating the brake?

$$P_V = \frac{T \times n_s}{9,55} \times s \Rightarrow n_s = \frac{9,55 \times P_V}{T \times s} \Rightarrow n_s = \frac{9,55 \times 23 \text{ W}}{1,5 \text{ Nm} \times 1} = 146 \text{ min}^{-1}$$

The brake can slip permanently with a rotation speed of 146 min^{-1} . Starting out from this result the average paper speed (dependent on the diameter of the roll of paper) can now be calculated.

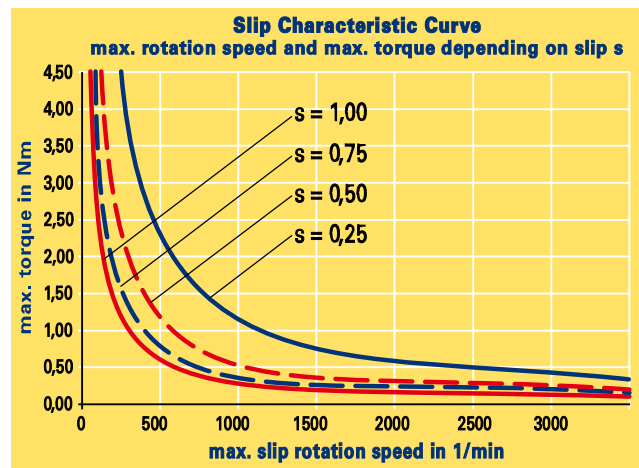

Example 2:

A hysteresis clutch of type HSV4a is applied in a bottle capping machine. One work cycle lasts 8 seconds. 6 seconds of this the clutch is engaged, 2 seconds the inner and the outer part are rotating relatively to each other. This 2 seconds are the actual load cycle of the clutch – the clutch is

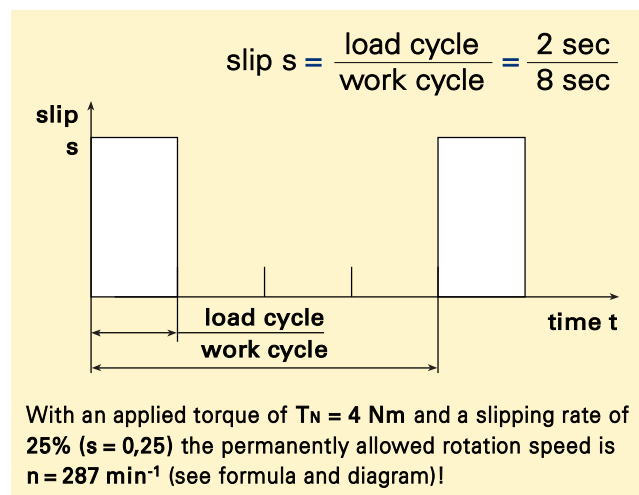

Log on to
www.gerwah.com
for:

- Complete catalogue info
- 3D-CAD product drawings
- Calculation software
- Product and corporate news
- And much more

